

## Manual jib cranes up to 125 kg

LRAV wall jib cranes

LRAP column jib cranes



Arm in aluminium  
LR86 up to 80 kg

Arm in aluminium  
LR113 up to 125 kg

Jib arm LRAV (mm)

Type	Load, kg	A	C	D	E	F	L	N	Arm profile	Weight (kg)
LRAV2/80	40-80	2000	577	507	110	150	14	3035	LR86	15
LRAV3/80	40-80	3000	577	507	110	150	14	3035	LR86	19
LRAV4/40	40	4000	577	507	110	150	14	3035	LR86	22
LRAV5/40	40	5000	577	507	110	150	14	3035	LR86	27
LRAV4/60	60	4000	577	507	110	150	14	3035	LR86	23
LRAV6/40	40	6000	860	800	150	200	18	3050	LR113	65
LRAV4/80	80	4000	860	800	150	200	18	3050	LR113	55
LRAV5/80	80	5000	860	800	150	200	18	3050	LR113	60
LRAV2/125	125	2000	860	800	150	200	18	3050	LR113	45
LRAV3/125	125	3000	860	800	150	200	18	3050	LR113	50

Column for LRAV (mm)

Type	For jib arm*	B	J	H	J	K	M	Weight (kg)
LPM15361	LRAV2/80	3610	250	200	20	18	M12	95
LPM15361	LRAV3/80	3610	250	200	20	18	M12	95
LPM15361	LRAV3-4/40	3610	250	200	20	18	M12	95
LPM15361	LRAV5/40	3610	250	200	20	18	M12	95
LPM15361	LRAV4/60	3610	250	200	20	18	M12	95
LPM20386	LRAV6/40	3860	300	250	20	24	M16	145
LPM20386	LRAV4/80	3860	300	250	20	24	M16	145
LPM20386	LRAV5/80	3860	300	250	20	24	M16	145
LPM20386	LRAV2/125	3860	300	250	20	24	M16	145
LPM20386	LRAV3/125	3860	300	250 </td <td>20</td> <td>24</td> <td>M16</td> <td>145</td>	20	24	M16	145

\* The jib crane includes arm and bracket, 1 pce trolley for lifting equipment, 3 pcs trolley for air tube with leather strap, end stop, load signs and 4 pcs bolts.



The wall mounted jib crane includes arm and bracket, 1 pce trolley for lifting equipment, 3 pcs trolley for air tube with leather strap, end stop, load signs and 4 pcs bolts.

LRAVL low-built wall jib cranes

LRAPL low-built column jib cranes



Low-built arm in aluminium  
LR86 up to 40 kg

Jib arm LRAVL (mm)

Type	Load, kg	A	C	D	E	F	L	N	Arm profile
LRAV2/40L	40	2000	300	232	110	150	Ø14	B-300	LR86
LRAV3/40L	40	3000	300	232	110	150	Ø14	B-300	LR86
LRAV3,5/40L	40	3500	300	232	110	150	Ø14	B-300	LR86

Column for LRAVL (mm)

Type	For jib arm*	B	G	H	J	K	M
LPM15361L	LRAV2/40L	Custom made	250	200	20	Ø18	M12
LPM15361L	LRAV3/40L	Custom made	250	200	20	Ø18	M12
LPM15361L	LRAV3,5/40L	Custom made	250	200	20	Ø18	M12

\* The jib crane includes arm and bracket, 1 pce trolley for lifting equipment, 3 pcs trolley for air tube with leather strap, end stop, load signs and 4 pcs bolts.

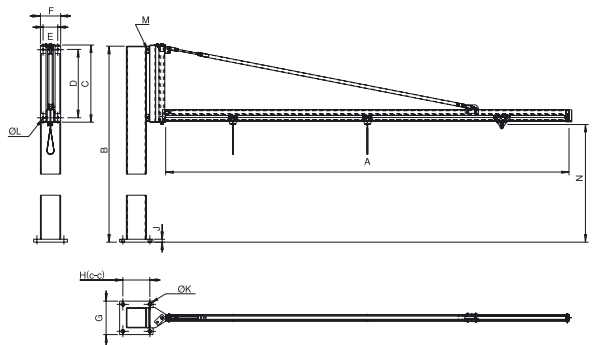

A twin brace is automatically included in the installation when certain rated SWL's are exceeded.

UVM low-built wall jib cranes  
 UPM low-built column jib cranes



Low-built arm in steel LR120 up to 80 kg

Jib arm UVM (mm)

Type	Load, kg	A	C	D	E	F	L	N	Arm profile
UVM2/80	80	2000	521	416	150	200	Ø18	B-185	LR120
UVM3/80	80	3000	521	416	150	200	Ø18	B-185	LR120
UVM4/60	60	4000	521	416	150	200	Ø18	B-185	LR120

Column for UVM (mm)

Type	For jib arm*	B	G	H	J	K	M
LPM15361U	UVM2/80	Custom made	300	250	20	Ø24	M16
LPM15361U	UVM3/80	Custom made	300	250	20	Ø24	M16
LPM15361U	UVM4/60	Custom made	300	250	20	Ø24	M16

\* The jib crane includes arm and bracket, 1 pce trolley for lifting equipment, 3 pcs trolley for air tube with leather strap, end stop, load signs and 4 pcs bolts.

LRAVU low-built wall jib cranes  
 LRAVU low-built column jib cranes



Low-built arm in aluminium LR113 up to 25 kg

Jib arm LRAVU (mm)

Type	Load, kg	A	C	D	E	F	L	N	Arm profile
LRAVU2/25	25	2000	441	341	110	150	Ø14	B-165	LR113
LRAVU3/25	25	3000	441	341	110	150	Ø14	B-165	LR113

Column for LRAVU (mm)

Type	For jib arm*	B	G	H	J	K	M
LPM15361A	LRAVU2/25	Custom made	250	200	20	Ø18	M12
LPM15361A	LRAVU3/25	Custom made	250	200	20	Ø18	M12

\* The jib crane includes arm and bracket, 1 pce trolley for lifting equipment, 3 pcs trolley for air tube with leather strap, end stop, load signs and 4 pcs bolts.

## Project planner:

A manually operated jib crane is most effective when the outer part (2/3) of the arm is used!

Do not over-dimension. No need to push around excessive weight.

If the area to be covered is large, consider a crane system instead of a jib crane.

The rated capacity of a system is based on handling a load with the specified weight, plus the weight of the lifting equipment (estimated at max 15% of rated capacity) and with a hoist speed (impact estimated to max 25% of rated capacity). **NEVER EXCEED** the rated capacity!

